



CITY OF NEW HOPE COMMUNITY DEVELOPMENT

4401 Xylon Ave N • New Hope MN 55428 • Phone: 763-531-5127 • Fax: 763-531-5136

• newhopemn.gov • newhopeinspections@newhopemn.gov

DRIVEWAY APPLICATION

PROCESS

- Driveway must be 3-feet off property lines.
- Driveways that are being altered to within 5-feet of the property line must have property pins located and marked for inspection.
- If any alterations are made to the curb a separate Curb Alteration Application is required. (Refer to handouts attached).

Permit# _____

Received Application _____

Received Payment _____

For Office Use Only

INCLUDE THE FOLLOWING ITEMS:

- ✓ **Driveway Application (this sheet) filled out completely.**
- ✓ **2 sets of plans showing property lines and setbacks.**
- ✓ **Payment (see below)**

PROPERTY INFORMATION

Property Address: _____

- Commercial Property Residential Property
 I am the Contractor I am the Property Owner

PROPERTY OWNER INFORMATION

Property Owner: _____
 Contact Name: _____
 Address: _____
 City: _____
 State: _____ Zip Code: _____
 Phone: _____
 Email: _____

CONTRACTOR INFORMATION

Business Name: _____
 Contact Name: _____
 Address: _____
 City: _____
 State: _____ Zip Code: _____
 Phone: _____
 Email: _____

WORK INFORMATION

New Replace Existing Alteration Other: _____

Description of Work: _____

Distance from Side Property Line: _____ Start Date: _____

Width at Boulevard: _____ Estimated Completion Date: _____

REQUIRED INSPECTIONS *COMPLETED BY CITY STAFF*

Site Final Other(s): _____

Conditions of Approval: _____

Approved By: _____ Date: _____

(Continue on next page)



CITY OF NEW HOPE COMMUNITY DEVELOPMENT

4401 Xylon Ave N • New Hope MN 55428 • Phone: 763-531-5127 • Fax: 763-531-5136

• newhopemn.gov • newhopeinspections@newhopemn.gov

DRIVEWAY APPLICATION

NOTICE

- **24-hour notice is required for all inspections.**
- **Driveway site inspection required.** Contact New Hope Inspections Department at 763-531-5127 to schedule.
- **Before you dig**, contact Gopher State One Call at 651-454-0002.
- Driveways that are being altered to within 5-feet of the property line must have property pins located and marked for inspection.
- Driveways and curb cuts/approaches must be at least 3-feet from the side property lines.
- Driveways on corner lots must be at least 40-feet from the intersection of the property lines.
- All parking areas, driveways, and driveway aprons must be constructed and surfaced with concrete, asphalt, paving block, or other forms of concrete in compliance with city construction specifications. All driveways and parking stalls must be surfaced with, at minimum, a 6-inch class 5 base and 2-inch asphalt topping.
- Curb cut accesses may not exceed the following width dimensions measured at the property line:
 - Residential: 24-feet
 - Residential single-family with 3-car garage: 28-feet
 - Commercial/Industrial: 26-feet

FEE SCHEDULE

Driveway \$25.00

Fees Due Upon Application	\$25.00
----------------------------------	----------------

Signature: _____ **Date of Application:** _____

PAYMENT

- Check** (Make payable to City of New Hope. Mail Attn: Inspections Department to 4401 Xylon Ave N, New Hope, MN 55428)
- Credit Card** (Fill in information below)
 - Credit Card Number: _____ Expiration Date: _____
 - Billing Address: _____
 - Signature: _____ Name (Print): _____

CITY OF NEW HOPE COMMUNITY DEVELOPMENT

4401 Xylon Ave N • New Hope MN 55428 • Phone: 763-531-5127 • Fax: 763-531-5136

• newhopemn.gov • newhopeinspections@newhopemn.gov



DRIVEWAY APPLICATION

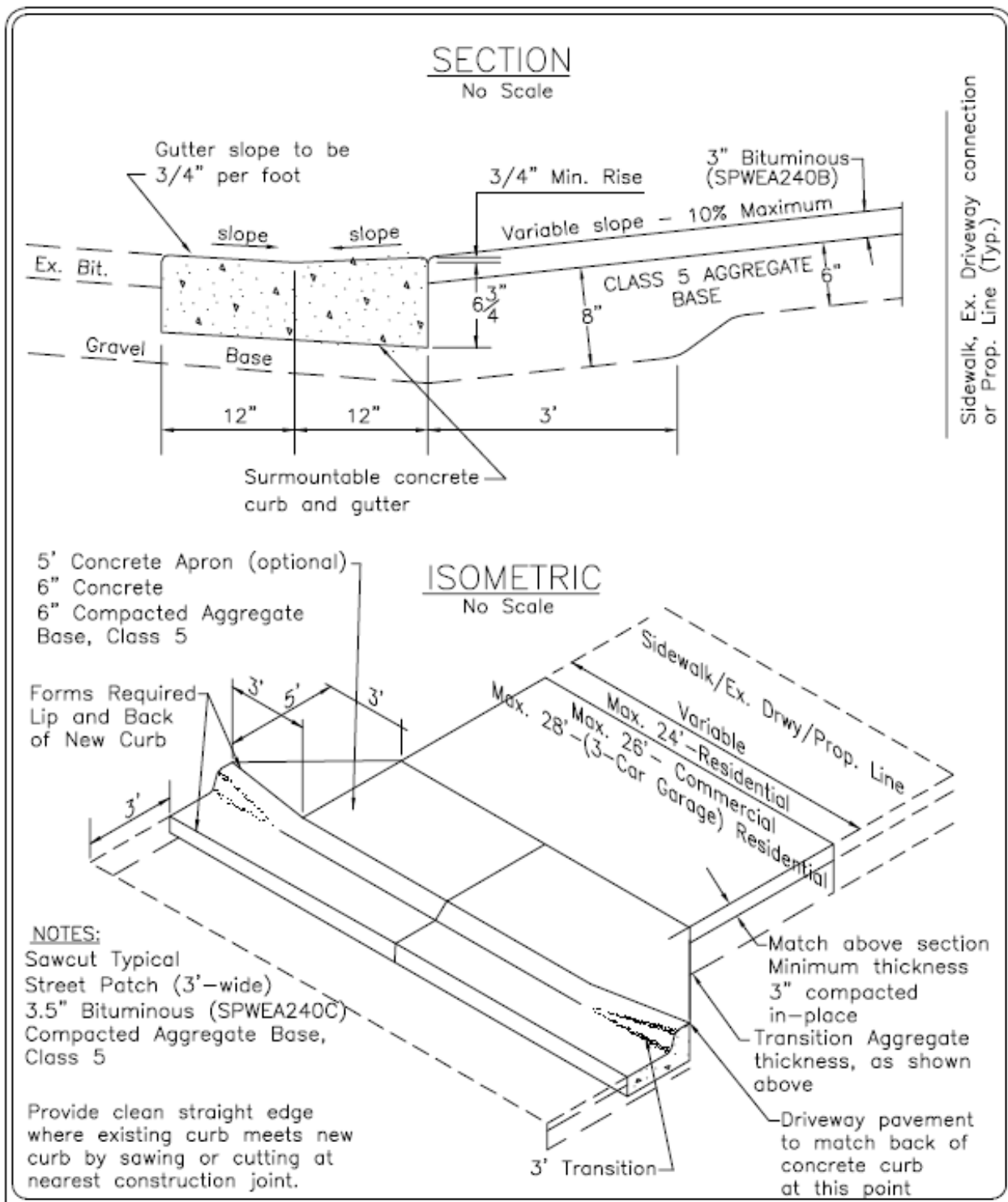

RESIDENTIAL DRIVEWAY WITH APRON

LAST REVISION:
AUG. 2019

CITY OF NEW HOPE, MN

PLATE NO.
STR-10A



CITY OF NEW HOPE COMMUNITY DEVELOPMENT

4401 Xylon Ave N • New Hope MN 55428 • Phone: 763-531-5127 • Fax: 763-531-5136

• newhopemn.gov • newhopeinspections@newhopemn.gov

DRIVEWAY APPLICATION

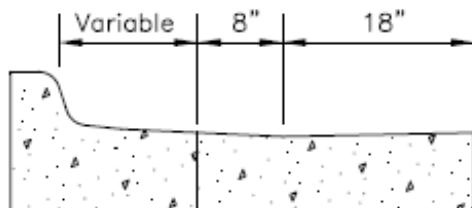
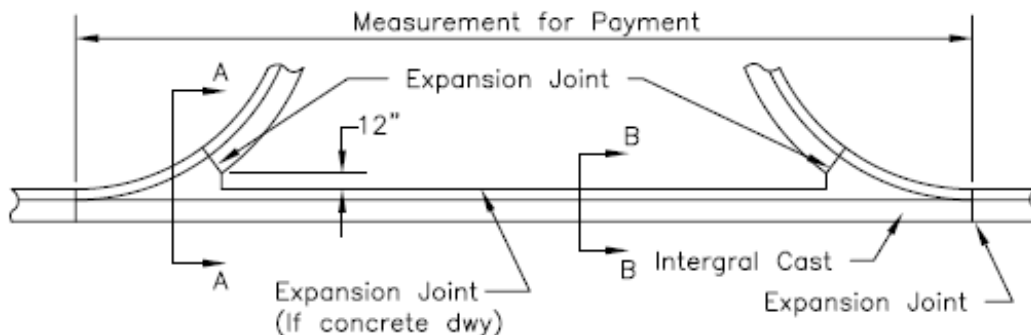

SECTION A-A
THRU B618 C&G

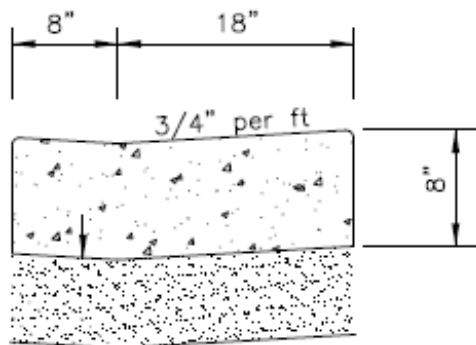

SECTION B-B
THRU
CONCRETE GUTTER

6" Min. Aggregate Base

**Bonestroo
Rosene
Anderlik &
Associates**
Engineers & Architects
St. Paul, Minnesota

STANDARD DETAILS
COMMERCIAL DRIVEWAY

Last Revision:
Nov 2004

BRA Plate No.
—

City Plate No.
—

NEW HOPE, MINNESOTA